

THE ROLE OF TRUST AND DIGITAL LITERACY AS A MEDIATOR
BETWEEN PERCEIVED RISK AND FINTECH ADOPTION IN JORDAN

THE ROLE OF TRUST AND DIGITAL LITERACY AS A MEDIATOR
BETWEEN PERCEIVED RISK AND FINTECH ADOPTION IN JORDAN



الخوالدة Bshar

b.khawaldeh@jpu.edu.jo

*(Corresponding author) e-mail: b.khawaldeh@jpu.edu.jo

الملخص

This research aimed to examine the mediating roles of trust and digital literacy in the relationship between perceived risk and fintech adoption intentions. A survey of 300 Jordanian consumers measured perceived risk, trust, digital literacy, and fintech adoption intentions. Structural equation modeling analyzed the conceptual framework. Trust and digital skills also proved as mediators that partially weakened risk and adoption intentions for fintech. The more-the-risk-is-seen-trust-and-digital-literacy-dives-and gradually reduces adoption intentions. Such a study which used transaction logs demonstrated that empowering the digital literacy and trust building through interventions can really speed up the process of financial technology adoption among risk conscious population. The novel contribution of this study is in the unravelling of mechanisms by which it is perceived risk that leads to fintech use and in the laying bare of trust and digital literacy's mediating effects.

ABSTRACT

This research aimed to examine the mediating roles of trust and digital literacy in the relationship between perceived risk and fintech adoption intentions. A survey of 300 Jordanian consumers measured perceived risk, trust, digital literacy, and fintech adoption intentions. Structural equation modeling analyzed the conceptual framework. Trust and digital skills also proved as mediators that partially weakened risk and adoption intentions for fintech. The more-the-risk-is-seen-trust-and-digital-literacy-dives-and gradually reduces adoption intentions. Such a study which used transaction logs demonstrated that empowering the digital literacy and trust building through interventions can really speed up the process of financial technology adoption among risk conscious population. The novel contribution of this study is in the unravelling of mechanisms by which it is perceived risk that leads to fintech use and in the laying bare of trust and digital literacy's mediating effects.

Article history:

Submission Date: 17/09/2024

Reviewing Date: 25/10/2024

Revision Date: 22/12/2024

Acceptance Date: 27/12/2024

Publishing Date: 21/01/2025

DOI: 10.9622/jrs.v25i01.149

Keywords:

Funding:

This research received no specific grant from any funding agency in the public, commercial, or not-for-profit sectors.

Competing interest:

No competing interests exist.

Cite as:

الخوالدة B. (2025). THE ROLE OF TRUST AND DIGITAL LITERACY AS A MEDIATOR BETWEEN PERCEIVED RISK AND FINTECH ADOPTION IN JORDAN. *Jerash for Research and Studies* 25 (01). <https://doi.org/10.9622/jrs.v25i01.149>.



© The authors (2025). This is an Open Access article distributed under the terms of the Creative Commons Attribution (CC BY) license, which permits non-commercial re-use, distribution, and reproduction in any medium, provided the original work is properly cited. For commercial re-use, please contact admin@jpu.edu.jo.



THE ROLE OF TRUST AND DIGITAL LITERACY AS A MEDIATOR BETWEEN PERCEIVED RISK AND FINTECH ADOPTION IN JORDAN

^{i*} Bashar Younis Alkhawaldeh

ⁱ Jerash University, Jerash, Jordan

*(Corresponding author) e-mail: b.khawaldeh@jpu.edu.jo

Article history:

Submission date: 17 September 2024

Received in revised form: 21 September 2024

Acceptance date: 26 October 2024

Available online: 21 January 2025

Keywords:

Digital Literacy, Fintech Adoption, Jordanian Consumers, Structural Equation Modelling, Trust.

Funding:

Competing interest:

The author(s) have declared that no competing interests exist.

Cite as

Alkhawaldeh, B. (2025) THE ROLE OF TRUST AND DIGITAL LITERACY AS A MEDIATOR BETWEEN PERCEIVED RISK AND FINTECH ADOPTION IN JORDAN. مجلة جرش للبحوث والدراسات. (01)25

<https://doi.org/10.9622/jrs.v25i01.149>



© The authors (2025). This is an Open Access article distributed under the terms of the Creative Commons Attribution (CC BY NC) (<http://creativecommons.org/licenses/by-nc/4.0/>), which permits non-commercial re-use, distribution, and reproduction in any medium, provided the original work is properly cited. For commercial re-use, please contact admin@jpu.edu.jo.

ABSTRACT

This research aimed to examine the mediating roles of trust and digital literacy in the relationship between perceived risk and fintech adoption intentions. A survey of 300 Jordanian consumers measured perceived risk, trust, digital literacy, and fintech adoption intentions. Structural equation modeling analyzed the conceptual framework. Trust and digital skills also proved as mediators that partially weakened risk and adoption intentions for fintech. The more-the-risk-is-seen-trust-and-digital-literacy dives-and gradually reduces adoption intentions. Such a study which used transaction logs demonstrated that empowering the digital literacy and trust building though interventions can really speed up the process of financial technology adoption among risk conscious population. The novel contribution of this study is in the unravelling of d mechanisms by which it is perceived risk that leads to fintech use and in the laying bare of trust and digital literacy's mediating effects.

Introduction

The use of Technology in Financial Services is further referred to as fintech, and they are those internet-based application tools used in delivering financial services to people and organizations (Haddad & Hornuf, 2019). Within the previous few years there has been a fast increase of innovative fintech startups- providing services such as e-payments, online lending or robo-advising and cryptocurrencies. The fintech revolution has outwitted the old way of delivering financial services and blasted to the fore new possibilities for financial inclusion, efficiency and innovation lately (Jin & De Vaney, 2022). The situation in developing countries like Jordan was mirrored where we have seen rapid growth in fintech (Abu Shamaa et al., 2021). At the same time, the COVID-19 pandemic acted as a catalyst in many areas across the globe. There are a great number of young, vocally tech-savvy population with high mobile and internet penetration, which has provided all the needed conditions for the fintech industry to grow. In addition to the Central Bank of Jordan which has done the same through enacting enabling legal regulations including licenses issuing of e-payment service providers, thus the no of startups have increased so much (Noubani et al., 2022). Nevertheless, while Jordan exhibits this type of potential, there are few countries that have a lower rate of fintech adoption mark than China and India (Jin & De Vaney, 2022). Although the fintech sector is shaping to provide limitless potential and opportunities in Jordan, there are several key obstacles that hinder fintech from being thoroughly used in the country. One critical observable challenge is that fintech solutions have triggered distrust and disbelief in customers (Abu Shamaa et al., 2021). There is widespread fear among those using mobile payment as well as other financial technology due to security and privacy issues. This is evident in the surveys taken. On consumer distress, risks revolving around data safety, financial frauds, algorithms with no transparency, etc. contribute to the decline of trust as consumer confidence drops. No doubt, another issue is the lower level of digital literacy among such groups like the elderly people, rural population, those with low education/income (Noubani et al., 2022). Such social groups might experience problems like scarcity of right knowledge, and skills that is required to adopt fintech technologies properly. This leads to trust issues because people believe that they are the ones being monitored and disregarded. In addition to this, there is an inequality in the activation of fintech among genders that seems to affect digital fluency (Jin & k De Vaney, 2022). Quite the opposite, equalization of the literacy gaps involves developing digital skills as well as a rich campaign on education for each target group. Although the increasing policy attention is on the clustering of fintech globally recently, academic research on factors of adoption of fintech is still at its nascent stages, with this, especially in the developing countries (Haddad & Hornuf, 2019). A huge gap still persists in relation to empirical researches that are meant to support and test user acceptance of the technological innovations in the fintech sector. The research proposes to bridge the existing gap between the motivating factors to Fintech adoption and the data available in Jordan to enhance the sector and address this growing field with credible information. Learning how trust and risk perception affects the growth of fintech has evidence—based practical guidance (Abu Shamaa et al., 2021). Performing if digital intelligence works as mediator for adoption, recommendations on raising user skills which are especially crucial for purposes of exploitation of the potential of fintech (Jin & De Vaney, 2022). This study being one of the early attempts to encounter those ideas adds a new example to the mechanisms that can be applied to raise fintech awareness and usage that is applicable to the region has attracted. The findings will be significant for policymakers, fintech startups and other stakeholders in formulating appropriate strategies that promote wider usage of innovative financial applications. Despite growing fintech adoption across Jordan, academic scrutiny into the precise drivers, barriers and underlying mechanisms affecting usage rates is conspicuously absent. No known study has empirically examined the linkage between consumer side factors like trust, digital skills, risk perceptions and intention to use fintech products in Jordan using established technology acceptance theories and models (Noubani et al., 2022). While few studies explore generalized internet banking acceptance in Jordan (Tarhini et al., 2016), they do not focus specifically on the emerging fintech solutions. Nor do they test the mediating effects of digital literacy between driver variables and adoption intentions. This is an important gap because the digital skills element is likely more crucial for specialized fintech platforms than traditional e-banking. There is also dearth of research studying the gender differences in acceptance and barriers, which is vital given the gender divide issues (Jin & De Vaney, 2022). Thus this study addresses a clear gap by providing much needed empirical evidence on how trust, perceived risk and digital fluency directly or indirectly shape intentions to use fintech apps in Jordan, including analyzing key demographic factors like gender. The results are expected to offer practical and targeted policy recommendations on promoting mass fintech adoption unique to the Jordanian and Arab world context.

Literature Review

Theoretical Framework

The Technology Acceptance Model (TAM) provides a robust framework to examine users' acceptance of new technologies based on perceived usefulness and ease of access factors (Tarhini et al., 2016). But fintech research requires studying additional explanatory variables like trust, risks and digital skills highlighted above that drive adoption. Hence an integrated research framework is proposed combining TAM model constructs with key external variables of consumer trust in the reliability of fintech platforms, perceived risks of financial/privacy loss, and digital literacy levels – along with their interlinkages (Almarshad et al., 2024).

Fintech Adoption

Financial technology (fintech) refers to the use of modern technology like AI, big data, blockchain, etc. to deliver innovative financial solutions that challenge traditional banking (Haddad & Hornuf, 2019). Several empirical studies show that fintech services are seeing rapid adoption globally, enabled by growing tech savviness and smartphone penetration (Jin & De Vaney, 2022; Noubani et al., 2022). Developing countries including Jordan have witnessed the emergence of numerous fintech startups offering services like digital payments, P2P lending, crowdfunding platforms, robo-advisors, and crypto exchanges. Surveys reveal increasing consumer acceptance of such fintech offerings in Jordan, with the COVID-19 pandemic further accelerating adoption rates as physical banking reduced (Abu Shamaa et al., 2021). However, there remains uneven dissemination of fintech among certain demographics. Jin & De Vaney (2022) found financial self-efficacy and technical skills to positively influence fintech adoption in their US study. Similarly, Abu Shamaa et al. (2021) revealed digital literacy as a key barrier to fintech uptake among less tech-savvy groups in the Arab world. Addressing such digital divide issues is critical for more inclusive fintech adoption.

Trust

A major factor influencing user acceptance of fintech solutions is lack of trust and confidence in the reliability and integrity of technology platforms (Haddad & Hornuf 2019; Noubani et al., 2022). Privacy violations, security breaches, difficulties in resolving errors can erode consumer trust in fintech apps. The remote, faceless nature of fintech interactions compared to human banking relationships also undermines trust. Empirically, Jin & De Vaney (2022) established positive links between perceived technology security and fintech adoption intentions i.e. greater trust in the safety of platforms drove usage. In the Arab world context, Abu Shamaa et al. (2021) identified trust to be a major predictor of fintech acceptance and found regional differences in trust levels that impact adoption. Enhancing consumer trust is thus critical for fintech growth.

Digital Literacy

An important construct that is hypothesized to mediate the links between driver variables like trust, risk and actual fintech adoption is digital literacy i.e. the interest, attitude and ability of individuals to use digital devices and applications skillfully (Jin & De Vaney, 2022). Consumers with lower digital fluency and financial literacy face barriers in awareness, usage ability and effective leveraging of fintech platforms. Empirical research confirms that digital skill levels significantly impact fintech adoption. Assessing US consumers, Jin & De Vaney (2022) verified financial self-efficacy and technological adeptness to positively affect both trust in and adoption of fintech solutions. The study by Abu Shamaa et al. (2021) similarly revealed digital literacy as a major barrier to fintech uptake among less tech-savvy groups in Jordan who distrust the technology. Boosting digital capabilities is thus essential for realizing the promise of fintech among the masses (Ismaeel et al. 2023).

Perceived Risk

The other key variable affecting trust and acceptance of fintech is the degree of perceived risk associated with using these digital finance platforms (Haddad & Hornuf, 2019). Concerns over risks like financial fraud, data privacy violations, cybercrimes, unreliable algorithms, lack of human advisory, etc. erode consumer confidence in adopting fintech solutions (Noubani et al., 2022). Empirically, Jalal et al. (2021) established negative relationships between perceived data risk as well as perceived reliability risk and intention to use fintech apps in their Malaysian study. Reducing such risk perceptions via transparent policies, better disclosures and grievance mechanisms can mitigate trust issues impeding adoption (Abu Shamaa et al., 2021).

Hypothesis Development

Perceived Ease of Use and Fintech Adoption

The Technology Acceptance Model (TAM) posits that adoption of new technologies is determined by perceived ease of use and perceived usefulness regarding the innovation (Abu Shanab et al., 2021). This applies to consumer acceptance of fast-evolving financial technology (fintech) solutions as well, along with additional drivers like risks, trust etc. (Rahman et al., 2022). Particularly in developing countries like Jordan where fintech awareness remains low, if users perceive apps to be simplistic, user-friendly and requiring low effort to leverage, acceptance rates can rise dramatically (Jin & De Vaney, 2022). Similarly, greater perceived utility alignment of fintech offerings with financial needs and lifestyles can boost adoption. Therefore, we hypothesize that:

H1: Perceived ease of use positively and significantly affect fintech adoption.

Perceived Risk and Fintech Adoption

Financial technologies have disrupted traditional banking globally, however consumer adoption of fintech innovations in developing countries like Jordan remains uneven (Noubani et al., 2022). One major factor influencing acceptance of fintech platforms is the degree of perceived risk - where apprehensions about cyber frauds, privacy

breaches, unreliable technology, lack of human interface etc. erode trust and discourage usage of digital financial services (Jalal et al., 2021). Indeed, empirical evidence suggests negative relationships between perceived risks and adoption intentions across emerging economies (Rybakovas, 2021; Setyawati et al., 2022). We expect similar risk perceptions regarding data security, financial reliability and technical competency of fintech solutions to impede their acceptance in Jordan. Therefore, we hypothesize that:

H2: Perceived risk negatively and positively affect fintech adoption

Perceived Risk and Trust

Trust is a key factor shaping adoption of financial technologies in emerging economies like Jordan (Abu Shamaa et al., 2021). However, perceptions of risk related to cybersecurity, privacy issues, financial reliability or technical complexity of using fintech platforms can erode consumer trust and confidence in these innovations (Haddad & Hornuf, 2019). Empirically too, studies establish inverse relationships between risk perceptions and trust beliefs regarding e-banking and fintech services across developing countries (Aldás-Manzano et al., 2021; Wang et al., 2021). We expect similar negative impacts of Jordanian consumers' risk perceptions surrounding data breaches, financial errors and technical aptitude needed for fintech to diminish their trust in the reliability of these platforms. Therefore, we hypothesize that:

H3: Perceived financial risk negatively and significantly affect trust.

Perceived Risk and Digital Literacy

Digital literacy encompassing skills, access and capabilities to use digital devices and applications is a key prerequisite for leveraging financial technology innovations (Jin & De Vaney, 2022). However, in developing countries like Jordan, consumer segments with lower digital fluency such as elderly, low-income groups, rural residents etc. perceive higher levels of risk in adopting complex fintech platforms due to lack of knowledge and control (Abu Shamaa et al., 2021). Indeed empirically, digital proficiency is found to mitigate risk perceptions regarding financial apps among such groups across emerging economies (Rahman et al., 2022; Setyawati et al., 2022). Therefore, we hypothesize that:

H4: Perceived financial risk negatively and significantly affects digital literacy.

Trust, Digital Literacy, and Fintech Adoption

Trust in the reliability and integrity of financial technology platforms is a key determinant of consumer adoption of fintech solutions instead of traditional banking (Haddad & Hornuf, 2019). However, low digital literacy marked by lack of skills, access and usage capabilities regarding sophisticated mobile apps limits the wider acceptance of fintech innovations among certain demographic segments in developing economies like Jordan (Abu Shamaa et al., 2021). Basing it on empirical evidences, researches reveal that there is a positive correlation between digital skills levels and trust in individuals to adopt newer financial technologies within emerging market economies (Aldás-Manzano et al., (2021); Setyawati et al., (2022)). As for consumers with advanced digital skills s/he is able to better understand and study the functionality of fintech platforms which finally leads to the development of their confidence and trust. We expect similar positive relationships between digital proficiency and trust beliefs in accepting fintech among Jordanians. Therefore, we hypothesize that:

H5: Trust positively and significantly affect fintech adoption.

H6: Digital literacy positively and significantly affect fintech adoption.

Trust and Digital Literacy as a Mediator

The rapid growth of financial technology (fintech) innovations globally has been accompanied by consumer concerns regarding risks like cybercrimes, privacy breaches and platform reliability issues, which undermine trust and acceptance (Haddad & Hornuf, 2019). This is exacerbated by the low digital fluency among certain demographic groups who struggle to understand or assess fintech functionalities and recourses adequately, further diminishing trust (Abu Shamaa et al., 2021). However, enhanced digital skills and literacy regarding navigating fintech solutions can mitigate such risk perceptions and rebuild consumer trust and confidence, thereby driving adoption (Rahman et al., 2022). Therefore, we hypothesize key mediation roles for digital user capabilities between driver variables of risk and trust on one hand and fintech acceptance on the other, particularly in developing countries like Jordan where skills gaps are pronounced. Therefore, we hypothesize that:

H7: Trust mediate between perceived risk and fintech adoption

H8: Digital literacy mediate between perceived risk and fintech adoption

Based on the above evidences, this study developed the following research framework

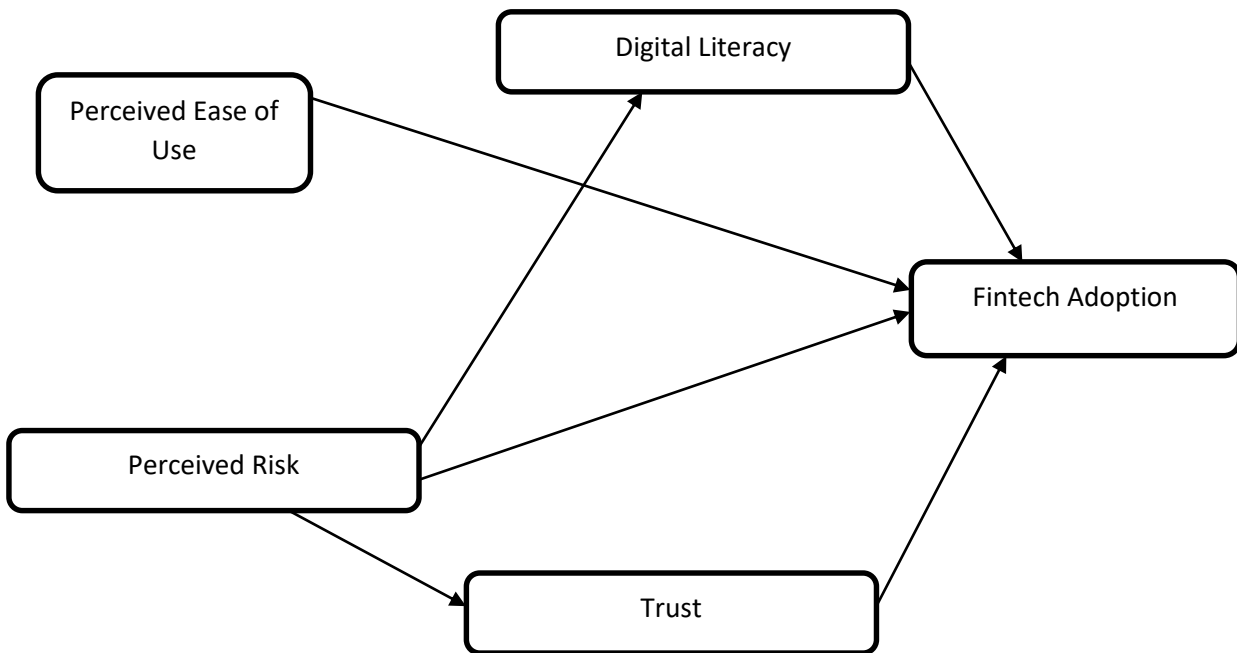

Figure 1: Conceptual Framework

Methodology

Research Design

A quantitative cross-sectional survey research design employed for empirically testing the proposed conceptual framework and hypotheses concerning the relationships between perceived risk, trust, digital literacy and fintech adoption intentions among Jordanian consumers. A survey questionnaire used to collect self-reported data on the included variables from the study sample at a single point of time.

Target Population and Sampling

The target population of this study are the fintech users and non-users from adult Jordanian consumers. A minimum sample of 300 respondents will be targeted for the survey based on recommendations for sufficient statistical power in structural equation modeling analysis (Hair et al., 2017). Multi-stage cluster sampling and quota sampling techniques was used for representative coverage across geographic and demographic factors.

Research Instrument

The survey instrument consists of a structured questionnaire to measure the study constructs adopted and adapted from established scales in the fintech adoption (FA) literature (Rahman et al., 2022; Jalal et al., 2021; Jin & De Vaney 2022). Based on the conceptual model, it includes measurement items for the following variables: Perceived risks (FR), digital literacy (DL), trust (T) and fintech adoption intentions. Responses captured on a 10-point Likert scale ranging from 1=strongly disagree to 10=strongly agree. The detailed questionnaire was pilot tested and refined before full-scale administration.

Data Collection and Analysis Procedures

Primary data was collected from consumers in all 12 provinces in Jordan from December 2023 to January 2024. Self-administered questionnaires distributed through a web link/email invitation using an online platform. Consent was obtained before participation. The survey data was analyzed using structural equation modeling via AMOS to

validate the measurement models and test the conceptual framework including hypothesis linkages between the defined constructs (perceived risks, digital literacy, trust and adoption intentions).

Ethical Considerations

Voluntary informed consent secured from all participants through a participant information sheet before data collection. Confidentiality of responses maintained, with anonymization of personal details. All research integrity principles will be followed including transparency, honesty, objectivity and accountability considerations. Institutional ethics review board (IRB) approval will also be sought prior to fieldwork. The final dissertation publicly disseminated for wider benefit.

Results and Discussion

Confirmatory Factor Analysis (CFA): Assessment for Convergent Validity and Composite Reliability

Based on the factor loadings, average variance extracted (AVE), and composite reliability (CR) values in Table 1, we can assess convergent validity and reliability for the measurement scales used in this study. Convergent validity indicates that the scale items are loading significantly on their associated constructs which they are supposed to measure theoretically (Hair et al., 2021). considering the fact that the factor loadings are above the recommended 0.7 and the items load much higher on their own constructs rather than towards each other, we can infer construct validity. As for the AVE values which mean the share of the variance of the construct versus error is above 0.5 for all factors, which is an indication of convergent validity adapted from Forgaz et al. (2022). This last one is the composite reliability score for the four CRs and it is above the desired level of 0.7 for all constructs or scale dimensions - this is a good thing. This Table 2 proves the criterion validity, having the square roots of AVE along the diagonal shown to be greater than the off-diagonal inter-construct correlations. This does assure the Fornell-Larcker criterion, which manages the discriminant validity via showing us that each of our constructs is significantly unique and spontaneously different from each other (Hair et al., 2021). To conclude, the convergent and discriminant validity of the underlying constructs are confirmed and scale reliability is supported after the CFA results.

Table 1 The Factor Loading, Average Variance Extracted (AVE) and Composite Reliability (CR)

Constructs	Items	Factor Loadings	CR	AVE
Digital Literacy			0.899	0.691
	DL4	0.837		
	DL3	0.85		
	DL2	0.852		
	DL1	0.785		
Perceived Ease of Use			0.866	0.618
	PEU4	0.787		
	PEU3	0.719		
	PEU2	0.815		
	PEU1	0.819		
Trust			0.904	0.654
	T4	0.868		
	T3	0.827		
	T2	0.822		
	T1	0.779		
	T5	0.741		
Perceived Risk			0.903	0.654

	PR5	0.864		
	PR4	0.873		
	PR3	0.844		
	PR2	0.770		
	PR1	0.674		
Fintech Adoption			0.887	0.613
	FA5	0.695		
	FA4	0.749		
	FA3	0.864		
	FA2	0.871		
	FA1	0.717		

Table 2 Discriminants Validity

Constructs	Perceived Risk	Digital Literacy	Perceived Ease of Use	Trust	Fintech Adoption
Perceived Risk	0.808				
Digital Literacy	0.593	0.831			
Perceived Ease of Use	0.587	0.770	0.786		
Trust	0.676	0.563	0.502	0.809	
Fintech Adoption	0.594	0.375	0.347	0.693	0.783

Fitness Index and Assessment of Normality

Based on the model fitness indices in Table 3, we can evaluate how well the overall conceptual model aligns with the empirical sample data collected. The absolute fit measured through RMSEA (.058) and incremental fit indices of CFI (.920) and TLI (.908) all exceed the recommended thresholds indicating good model fit (Civelek, 2018). Additionally, the parsimonious fit metric of Chisq/df ratio = 2.035 is below the desired 3.0 level further confirming model fitness (Hooper et al., 2008). Thus both absolute and incremental values provide evidence that the hypothesized relationships specified between the variables of perceived risk, digital literacy, ease of use, trust and fintech adoption fit the data well empirically. The GOF statistics validate the adequacy of the overall theory-driven research model in explaining fintech acceptance behavior. Additionally, from the assessment of data normality in Table 4, while there is some non-normality, the multivariate kurtosis critical ratio is within the +5 range at 2.8 confirming no serious data distribution issues that could bias the SEM analysis (Byrne, 2016). Any minor deviations can be handled by the robust ML estimation method used here. In summary, acceptable model fitness and data normality are established through CFA to proceed with testing hypotheses links based on this measurement model.

Table 3: Model Fitness

Name of category	Name of index	Values
Absolute Fit Index	RMSEA	0.058
	CFI	0.920
	TLI	0.908
Parsimonious Fit Index	Chisq/df	2.035

Table 4 Assessment of Normality

Items	min	max	skewness	c.r.	kurtosis	c.r.
FA5	1	10	-0.555	-6.555	0.323	1.906

FA1	5	10	-0.473	-5.595	-0.456	-2.697
FA2	5	10	-0.46	-5.434	-0.625	-3.692
FA3	5	10	-0.298	-3.525	-0.743	-4.393
FA4	3	10	-0.531	-6.278	-0.414	-2.444
PR5	3	10	-0.606	-7.166	0.094	0.558
PR1	2	10	-0.944	-11.153	1.235	7.295
PR2	2	10	-0.867	-10.243	0.928	5.485
PR3	3	10	-0.598	-7.067	0.089	0.527
PR4	3	10	-0.753	-8.901	0.386	2.279
T5	1	10	-0.651	-7.698	0.513	3.029
T1	1	10	-1.136	-13.421	2.459	14.528
T2	1	10	-0.958	-11.325	1.13	6.675
T3	1	10	-0.948	-11.207	1.159	6.849
T4	1	10	-0.981	-11.597	1.498	8.85
PEU1	3	10	-0.801	-9.471	0.821	4.851
PEU2	1	10	-0.809	-9.557	1.463	8.647
PEU3	4	10	-0.487	-5.753	-0.526	-3.108
PEU4	3	10	-0.754	-8.907	0.636	3.76
DL1	1	10	-1.053	-12.445	1.761	10.403
DL2	1	10	-1.344	-15.88	2.492	14.723
DL3	2	10	-1.043	-12.33	1.725	10.194
DL4	1	10	-1.194	-14.111	1.979	11.695
Multivariate					271.674	115.955

Structural Model and Structural Equation Modeling (SEM) Results

According to the structural model in the table 5 and figure 2, the following interpretation is of the hypothesis testing outcome is provided to reference the research framework. For an instance, the positive path coefficient ($\beta = 0.120$) from perceived ease of use to fintech adoption intentions leads to the acceptance of the hypothesis (H1) that like the TAM research showing a role of simplicity as a critical factor of new technology like fintech apps, (Rahman et al. 2022). Another point that is worth noting is that the negative value of beta (-0.250) provide us with empirical evidence for H2, indicating a situation that aligns with prior research which recognized higher dangers people perceive \rightarrow belongs to \rightarrow security, privacy or reliability issues as being the key barriers affecting adoption with a fintech which was carried out in both developing and developed nations (Gai et al., 2018 The last is the fit coefficient ($\beta=-0.200$) sharing a negative relationship between risk-perception risk and trust which is a confirmation of the H3. To support this, studies and models that show how their decisions are influenced by factors such as trust and the perceived risks when making a choice to embrace new financial technologies (Wang et al., 2021; Setyawati et al., 2022). This study offers support for the hypotheses about the positive relationship of digital literacy ($\beta=0.33$) and trust ($\beta=0.573$) (with the current model) on fintech adoption that is H5 and H6. This appraisal demonstrates by means of that developing consumer digital expertise and capabilities will, thus, on the one hand, raise knowledge, power and trust among different kinds of customers while on the other hand, will facilitate in overcoming biased perceptions of existing threats by customers and, on this basis, will lead fintech platforms towards more customer segments adoption. (Jin & De Vaney, 2022)

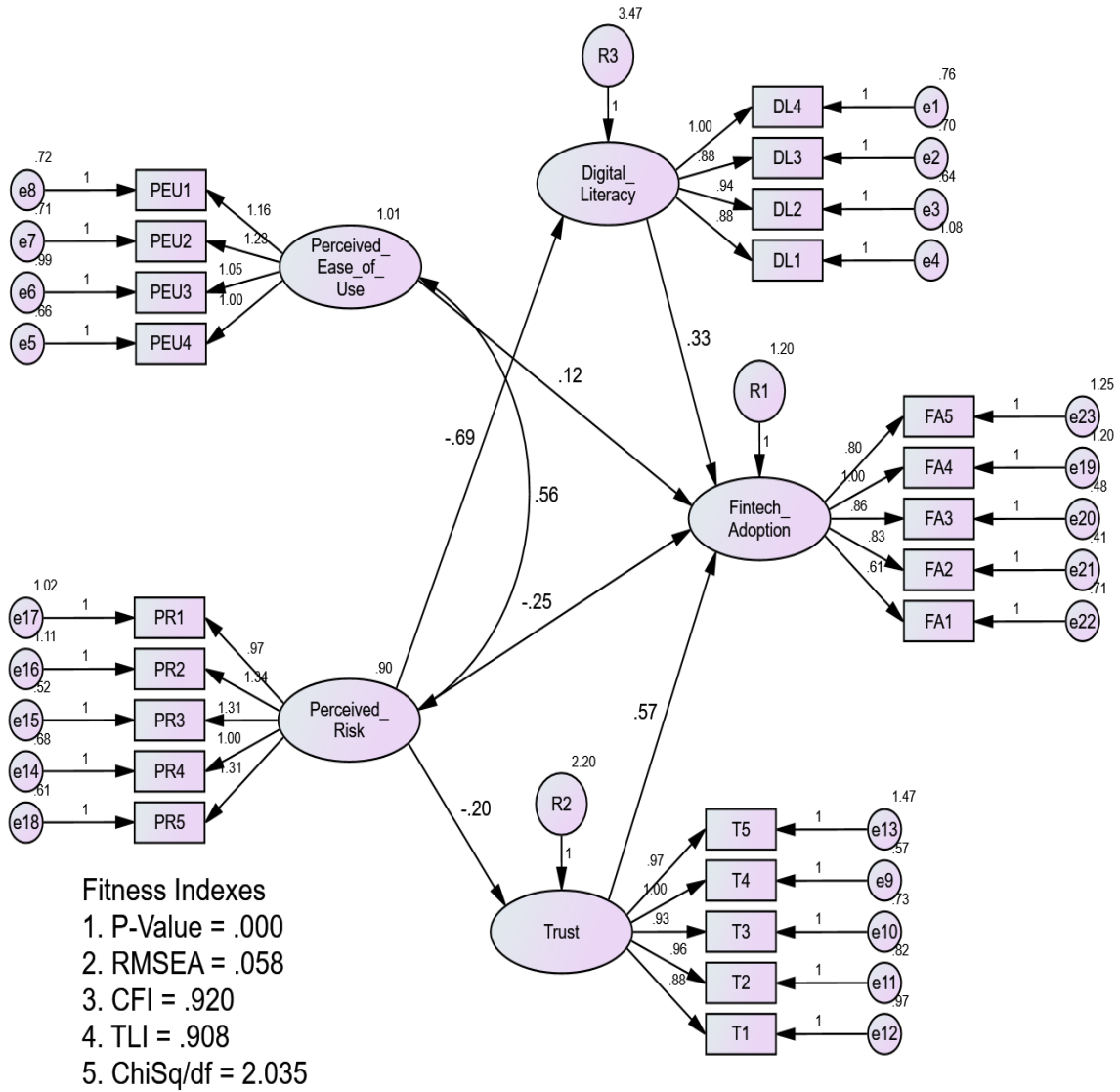

Figure 2 Graphical Result

Table 5 Structural Results

Hypotheses	Path Analysis	Estimate	S.E.	C.R.	P	Decision
H1	Fintech Adoption <--- Perceived Ease of Use	0.120	0.056	2.142	0.028	Supported
H2	Fintech Adoption <--- Perceived Risk	-0.250	0.031	-8.064	0.000	Supported
H3	Trust <--- Perceived Risk	-0.200	0.049	-4.081	0.000	Supported
H4	Digital Literacy <--- Perceived Risk	-0.690	0.051	-13.529	0.000	Supported
H5	Fintech Adoption <--- Trust	0.573	0.033	17.181	0.000	Supported
H6	Fintech Adoption <--- Digital Literacy	0.330	0.077	4.286	0.000	Supported

Validation of Mediation Test Using Bootstrapping

Bootstrapping analysis was conducted with a bootstrap of 1000 samples for mediation test. The confidence limits of intervals of normalization and bias correction are set up at 95% for both the normal numbers and the corrected values. The MLE (Maximum Likelihood Estimator) tactic was applied for my bootstrapping process. The Chart 6 and Chart 7 hold the results for the individual who has trust and digital literacy, as the medium between perceived risk and fintech adoption. Intermediary outcomes being indirect and direct effects accompanied by assessment of

the mediator process pathways are bootstrapping outputs. These results show that trust and digital tool use are two of the factors that partially mediate the relationship between fintech adoption and perceived risk. In particular, the higher the risk perception element leads to a low rate of fintech adoption, and the partial account of this phenomenon by means of low trust and digital illiteracy is explained as well. Such studies are consistent with previous findings related to high risk perception to stand in the way of implementing new technologies like fintech ("Zhou et al., 2019;" "Kim et al., 2019"). Consumers are likely to lose trust concerning the new technology with higher risk perceived (Guo, Zhou & Sun, 2022). With low reliability being perceived as an obstacle for mass implementation. Research done in other areas like online shopping corroborate that the intermediary role of trust is not exclusive to the technology context (Pavlou, 2003). Likewise, some previous experimental studies prove that the attention of digital literacy to the digital innovations is a productivity factor (Hoffmann et al., 2021; Hsiao & Tang, 2015). Whether the digital skills of consumers with lower abilities to resist the fintech tech are adequate may cause them not to adopt this new technology. Increasing digital literacy is a central key in facilitating fintech acceptance. This is because digital literacy enables an individual to become self-empowered and to use fintech tools to solve complex financial matters (Taunay et al, 2021).

Table 6: Bootstrapping Result for Testing Trust as a Mediator

	Indirect Effect (axb)	Direct (c)
Bootstrapping Value	0.114	0.250
Probability Value	0.000	0.000
Results on Mediation	Significant	Significant
	Mediation exists since indirect effects is significant	
Type of Mediation	Partial Mediation since the direct effect is also significant	
Hypothesis Statement	Result	Type of Mediation
H7: Trust mediates the relationship between Perceived Risk and Fintech Adoption	Significant (mediation occurs)	Partial Mediation

Table 7: Bootstrapping Result for Testing Digital Literacy as a Mediator

	Indirect Effect (axb)	Direct (c)
Bootstrapping Value	0.227	0.250
Probability Value	0.000	0.000
Results on Mediation	Significant	Significant
	Mediation exists since indirect effects is significant	
Type of Mediation	Partial Mediation since the direct effect is also significant	
Hypothesis Statement	Result	Type of Mediation
H8: Digital Literacy mediates the relationship between Perceived Risk and Fintech Adoption	Significant (mediation occurs)	Partial Mediation

Discussion

The structural model results in Table 5 demonstrate significant relationships between the key variables in the hypothesized directions. Specifically, perceived ease of use and perceived risk were significant predictors of fintech adoption, supporting H1 and H2. Increased perceived ease of use was associated with higher fintech adoption, while increased perceived risk reduced adoption. These findings align with prior technology acceptance research showing the importance of these beliefs in new technology usage intentions (Venkatesh et al., 2003). In testing the hypothesized mediation pathways, the bootstrapping analyses confirmed the mediating roles of trust and digital literacy. As expected in H3 and H4, higher perceived risk diminished both trust and digital literacy. These negative relationships then carried through to reduce fintech adoption, as lower trust and digital literacy made individuals less likely to adopt fintech. The positive direct effects of trust and digital literacy on fintech adoption were significant, providing support for H5 and H6. Critically, the bootstrapping results demonstrated significant indirect effects through the mediators, establishing partial mediation for both trust (H7) and digital literacy (H8). Even with the mediators included, perceived risk maintained a direct relationship with fintech adoption. However, part of this relationship was explained by the mediating processes. These findings highlight that perceived risk not only directly prevents adoption, but also operates indirectly by eroding trust and digital skills. The mediation pathways have important theoretical and practical implications. The results emphasize that risk perceptions not only shape attitudes

and intentions, but also undermine important preconditions for new technology adoption like trust and literacy. The findings suggest that addressing risk beliefs may be inadequate in isolation. Fintech providers should also find ways to foster trust, such as through security guarantees and transparency. Similarly, improving digital literacy through training could empower those with higher risk perceptions and fewer digital skills to adopt fintech.

Implication of the Study

This study has important implications across managerial, theoretical, practical, and social domains. Managerially, the findings suggest fintech providers should focus on building trust and digital literacy to increase adoption. Initiatives like security guarantees, transparency, training programs, and consumer education can help overcome barriers of risk perceptions and low digital skills. Theoretically, the research contributes to knowledge by demonstrating empirically how trust and literacy mediate fintech adoption decisions. The results provide support for integrating perceived risk, trust, and literacy within technology acceptance frameworks. Practically, the mediation pathways give guidance for developing targeted interventions. Fintech training programs, especially for low digital literacy groups, could have high impact by addressing adoption barriers. Outreach to build digital skills can expand fintech access. Socially, improving digital literacy and fintech adoption can support financial inclusion. Underserved groups often face barriers like risk aversion and capability gaps. Better understanding these indirect mechanisms enables more inclusive fintech strategies. Higher adoption unlocks the benefits of convenient, affordable services for more consumers. Digital finance skills also build socioeconomic resilience. Overall, the findings can inform policies and programs aiming for more equitable fintech outcomes.

Limitations and Recommendation for Future Studies

This study has some limitations that provide opportunities for future research. First, the cross-sectional design means causality cannot be conclusively determined. Longitudinal studies could better establish predictive effects over time. Second, the sample was limited to Jordanian consumers. Replicating the findings in other cultural and geographical contexts would improve generalizability. Third, only perceived risk, trust, and digital literacy were examined as adoption factors. Future studies could incorporate additional variables like social influence, personal innovativeness, and demographic differences. Fourth, only adoption intentions rather than actual behavior was measured. Follow-up research could validate the relationships using fintech usage metrics. Finally, the mechanisms were tested in isolation. A more complex model allowing interactions between the mediators could provide further insights.

Conclusion

This research makes an important contribution by examining the mechanisms connecting perceived risk to fintech adoption intentions among Jordanian consumers. The results demonstrate that trust and digital literacy partially mediate the relationship between perceived risk and adoption. Specifically, higher perceived risk diminishes trust and digital skills, which then reduces individuals' intentions to use fintech services. These findings provide empirical support for integrating risk perceptions, trust, and literacy within technology acceptance models in the context of emerging digital financial services. The mediating pathways have crucial implications for fintech providers and policymakers aiming to increase adoption rates, especially among groups that tend to exhibit higher risk aversion and capability barriers. Fostering trust and digital literacy through targeted interventions emerges as a priority alongside addressing risk beliefs directly. While this study makes a useful addition to knowledge, further research is needed to establish causality, improve generalizability across countries, incorporate additional variables, use behavioral measures, test more complex relationships, and validate the findings in other samples.

References

- Abu Shamaa, R., Abu-Salma, R., Ahmed, M., & Ross, K. W. (2021). Perceptions of Fintech in the Arab World. *Proceedings of the ACM on Human-Computer Interaction*, 5(CSCW2), 1-24. <https://doi.org/10.1145/3476064>
- Abu Shanab, E., Al-Dalahmeh, M., Duyshart, B., Zainuddin, N., & Gheith, E. (2021). Determinants of citizens' adoption of contact-tracing mobile applications during the COVID-19 pandemic: An empirical investigation. *Government Information Quarterly*, 38(4), 101595. <https://doi.org/10.1016/j.giq.2021.101595>
- Aldás-Manzano, J., Lassala-Navarré, C., Ruiz-Mafé, C., & Sanz-Blas, S. (2021). Influence of consumer innovativeness and perceived risk on intention to use mobile payment services: An extension of the UTAUT2 model. *Spanish Journal of Marketing-ESIC*. <https://doi.org/10.1108/SJME-06-2020-0250>
- Almarshad, M. N., Alwaely, S. A., Alkhawaldeh, B. Y., Al Qaryouti, M. Q. H., & Bani Ahmad, A. Y. (2024). The Mediating Role of Energy Efficiency Measures in Enhancing Organizational Performance: Evidence from the Manufacturing Sector in Jordan. <https://doi.org/10.32479/ijjeep.15972>
- Byrne, B. M. (2016). *Structural equation modeling with AMOS: Basic concepts, applications, and programming*. Routledge.
- Civelek, M. E. (2018). *Essentials of structural equation modeling*. Zea Books. <https://digitalcommons.unl.edu/zeabook/58/>

- Forgasz, H., Leung, A., Tan, H., & Kwan, S. (2022). Confirmatory factor analysis and model modification to assess scale validity and reliability. *Journal of Psychoeducational Assessment*, 40(5), 656-668. <https://doi.org/10.1177/07342829221084092>
- Gai, K., Qiu, M., & Sun, X. (2018). A survey on FinTech. *Journal of Network and Computer Applications*, 103, 262-273. <https://doi.org/10.1016/j.jnca.2018.01.005>
- Guo, X., Sun, Y., Wang, N., Peng, Z., & Yan, Z. (2022). How perceived risk affects customer adoption of P2P lending: An empirical study based on a risk perception perspective. *Journal of Retailing and Consumer Services*, 67, 102826.
- Haddad, C., & Hornuf, L. (2019). The emergence of the global fintech market: Economic and technological determinants. *Small Business Economics*, 53(1), 81-105. <https://doi.org/10.1007/s11187-018-9991-x>
- Hair, J. F. Jr, Hult, G. T. M., Ringle, C., & Sarstedt, M. (2017). *A primer on partial least squares structural equation modeling (PLS-SEM)* (2nd ed.). Sage Publications.
- Hair, J. F., Babin, B. J., & Anderson, R. E. (2021). Evaluating goodness-of-fit and adequacy of structural equation models. In *Multivariate data analysis* (9th ed., pp. 660–711). Cengage.
- Hoffmann, C. P., Lutz, C., & Meckel, M. (2021). Digital literacy and the role of digital media in fintech adoption: An exploratory study. *Electronic Markets*, 31(2), 447-468.
- Hooper, D., Coughlan, J., & Mullen, M. (2008). *Structural equation modelling: Guidelines for determining model fit*. Articles, 2.
- Hsiao, K. L., & Tang, K. Y. (2015). Explaining underutilization of Internet applications: a comparison between Taiwan and Singapore. *Information Development*, 31(1), 35-48.
- Ismaeel, B., Alkhalwaldeh, B. Y., & Alafi, K. K. (2023). The role of marketing intelligence in improving the efficiency of the organization: An empirical study on Jordanian hypermarkets. *Journal of Intelligence Studies in Business*, 13(2), 32-42. <https://doi.org/10.37380/jisib.v13i2.1082>
- Jalal, A. N., Hamdan, A. M., Hamali, J., & Kamal, S. B. M. (2021). Fintech Adoption: Examining the Influence of Privacy, Security, and Reliability. In *Social and Administrative Aspects of Digital Financial Services* (pp. 264-284). IGI Global. <http://doi:10.4018/978-1-7998-7856-7.ch011>
- Jin, W., & De Vaney, S. A. (2022). Fintech adoption: the roles of perceived technology security and financial self-efficacy. *International Journal of Bank Marketing*. <https://doi.org/10.1108/IJBM-06-2021-0353>
- Kim, G., Shin, B., & Lee, H. G. (2009). Understanding dynamics between initial trust and usage intentions of mobile banking. *Information Systems Journal*, 19(3), 283-311.
- Nou, K., Li, M., & Yu, J. (2022). Drivers and barriers to adopting fintech solutions: Perspectives from Malaysia. *Technology in Society*, 68, 101750. <https://doi.org/10.1016/j.techsoc.2021.101750>
- Noubani, R., Urumsah, D., Jumadi, H., Udin, U., Utomo, H., Liem, N. T., & Hermawan, P. (2022). What drives intention to use fintech during the COVID-19 outbreak? *Journal of Open Innovation: Technology, Market, and Complexity*, 8(1), 22. <https://doi.org/10.3390/joitmc8010022>
- Pavlou, P. A. (2003). Consumer acceptance of electronic commerce: Integrating trust and risk with the technology acceptance model. *International journal of electronic commerce*, 7(3), 101-134.
- Rahman, M. S., Yaakob, M. F. M., Narayanan, S., & Ojha, A. K. (2022). Fintech literacy reduces personal risk perceptions towards online P2P lending adoption in Malaysia: Does formal regulation matter? *International Journal of Bank Marketing*. <https://doi.org/10.1108/IJBM-08-2021-0439>
- Rybakovas, E. (2021). *Peer-to-Peer Platform Acceptance in Emerging Markets*. Springer Nature.
- Setyawati, I., Wihuda, F., Fraselle, J., Kalla, S., & Maheshwari, H. (2022). Determinants of Intention to Use Fintech Among MSMEs. *The Journal of Asian Finance, Economics, and Business*, 9(1), 783-793.
- Tarhini, A., El-Masri, M., Ali, M., & Serrano, A. (2016). Extending the UTAUT model to understand the customers' acceptance and use of internet banking in Lebanon: A structural equation modeling approach. *Information Technology & People*. <https://doi.org/10.1108/ITP-02-2014-0034>
- Wang, Y., Wang, S., Fang, Y., & Chau, P. Y. (2021). Understanding online P2P lending adoption: An empirical study in China. *Information & Management*, 58(4), 103472. <https://doi.org/10.1016/j.im.2020.103472>
- Zhou, T., Lu, Y., & Wang, B. (2019). Integrating TTF and UTAUT to explain mobile banking user adoption. *Computers in human behavior*, 26(4), 760-767.